

Caratteristiche tecniche - Tavolo realizzato in massello di noce americano o frassino e multistrato di pioppo impiallacciato. La versione rettangolare è sorretta da due basi e un traverso in noce americano o frassino con terminali delle basi e del traverso in ottone. La versione rotonda è sorretta da tre basi in noce americano o frassino con terminali delle basi in ottone. Piano in marmo, ebano o legno della stessa finitura scelta per la struttura. Su richiesta parti terminali in ottone inciso per tutte le versioni e vassoio girevole per la versione rotonda.

Technical features - Table made in solid American walnut or ash and veneered poplar plywood. The rectangular version is supported by two bases and a crosspiece in American walnut or ash, with leg and crosspiece tips in brass. The round version has three bases in American walnut or ash, with leg tips in brass. Top in marble, ebony or wood in the same finish chosen for the structure. Upon request, engraved brass end parts for all versions, and a rotating tray for the round version.

Nota - Specificare la finitura del legno, tra quelle presenti a campionario. Il piano in legno e ebano del tavolo rettangolare è diviso in n°6 settori. Il piano in marmo del tavolo rettangolare (2 lastre) è diviso in n°4 settori, intarsiato a croce in noce americano o frassino. Il piano in legno e ebano del tavolo tondo è diviso in n°3 settori. Il piano in marmo del tavolo tondo (1 lastra) è diviso in n°3 settori, intarsiato in noce americano o frassino. Per misure personalizzate richiedere quotazione.

Note - Wood finish to be specified from the available sample set. For the rectangular table, the wood and ebony tabletop is segmented into 6 panels, featuring a cross-shaped inlay in American walnut or ash. For the round table, the wood and ebony tabletop is segmented into 3 panels. The marble tabletop of the round table (single slab) is segmented into 3 panels, with an inlay in American walnut or ash. Custom dimensions available upon request; quotation required.



Gaspard rettangolare / rectangular

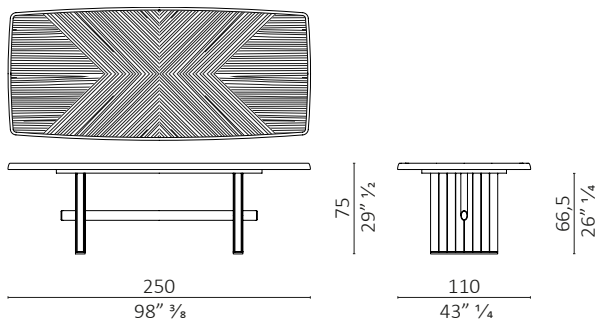

Gaspard rettangolare / rectangular

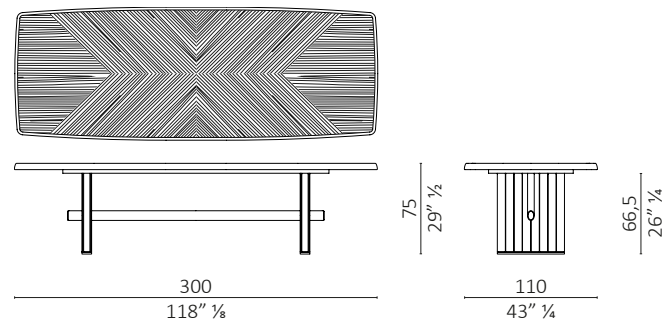

Gaspard rettangolare / rectangular

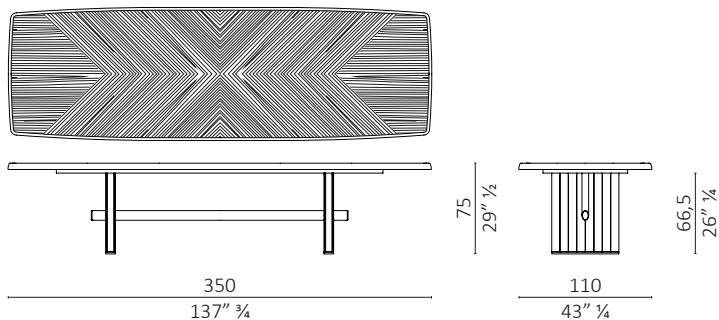

Gaspard rettangolare / rectangular

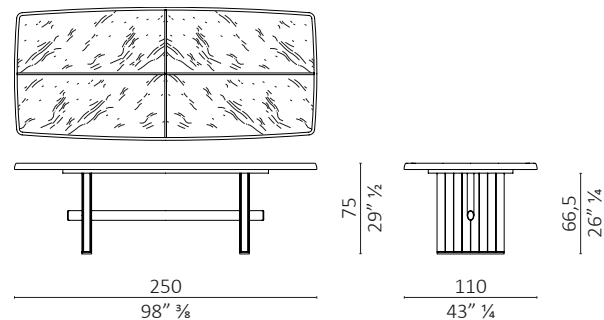

Gaspard rettangolare / rectangular

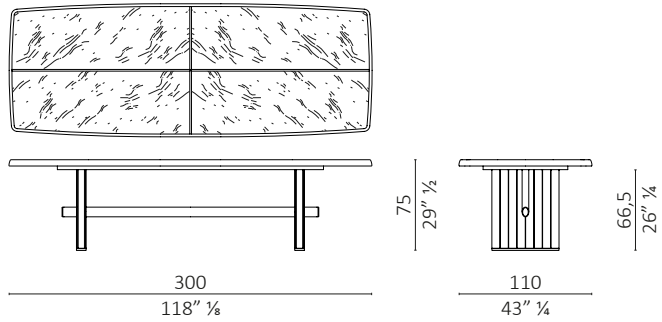

Gaspard rettangolare

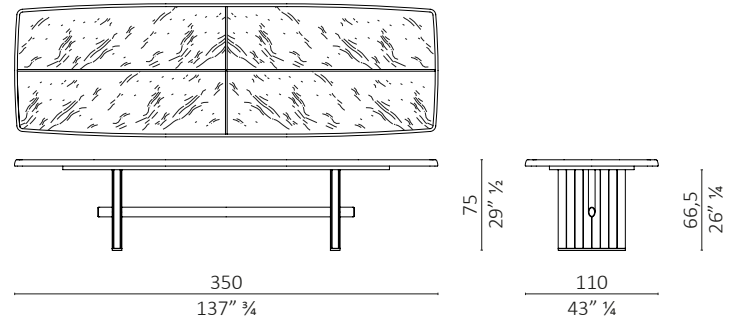

Gaspard rotondo / round

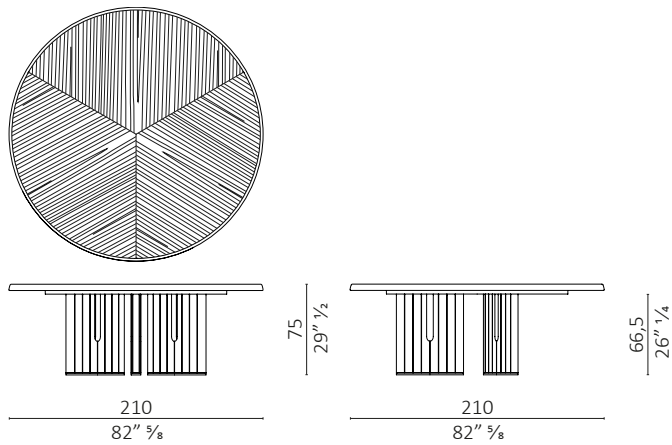

Gaspard rotondo / round

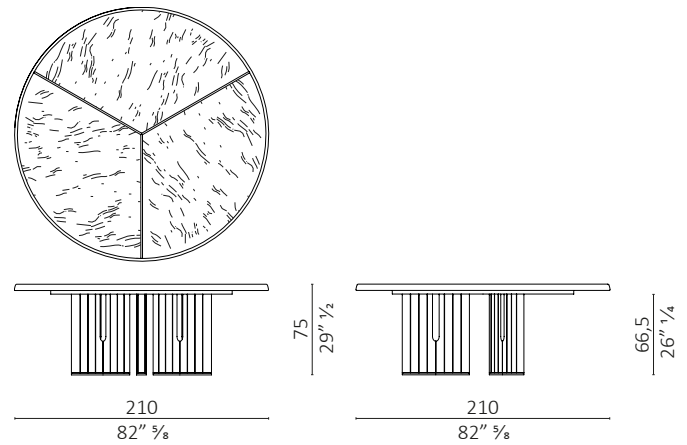

Accessori / Accessories

Vassoio girevole / Lazy susan Ø 120

Caratteristiche tecniche - Vassoio girevole in legno.

Technical features - Wooden swivel tray.

Nota - Disponibile per tavoli rotondi.

Note - Available for round tables.

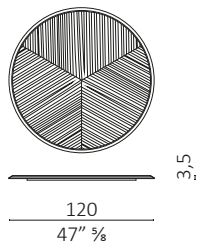

Ottone brunito spazzolato inciso / Engraved brushed burnished brass

Caratteristiche tecniche - Terminali delle basi in ottone spazzolato brunito con motivo a scacchi inciso.

Technical features - Leg tips in brushed burnished brass with engraved checkered pattern.

Nota - Disponibile per tavoli rotondi.

Note - Available for round tables.

Finiture / Finishes

Legno Noce / Wood Walnut

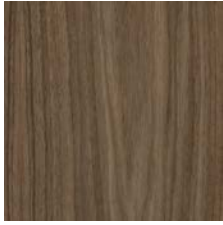

Noce
Walnut



Noce dark
Walnut dark



Noce moka
Walnut moka



Noce brown
Walnut brown

Legno Frassino / Wood Ash



Frassino sbiancato
Bleached ash

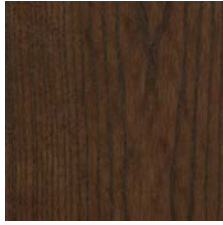

Frassino dark
Ash dark

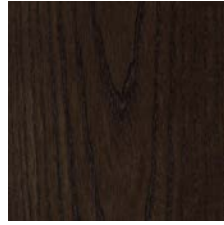

Frassino moka
Ash moka



Frassino brown
Ash brown

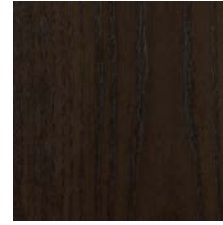

Frassino wengè
Ash wengè



Frassino black
Ash black



Frassino moka PF
Ash moka PF



Frassino wengè PF
Ash wengè PF

Legno Ebano / Wood Ebony



Ebano
Ebony

Marmo / Marble

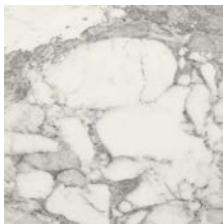

Cervaiola



Calacatta
Calacatta Oro

Finiture / *Finishes*

Metallo Ottone / *Metal Brass*



Ottone spazzolato
Brushed brass